

PRODUCT INFORMATION PACKET

Model No: 449TSTFS6002

Catalog No: E272

300 HP General Purpose Motor, 3 phase, 3600 RPM, 460 V, 449TS Frame, TEFC
Three Phase TEFC Motors



Regal and Marathon are trademarks of Regal Beloit Corporation or one of its affiliated companies.
©2020 Regal Beloit Corporation, All Rights Reserved. MC017097E

REGAL



Nameplate Specifications

Output HP	300 Hp	Output KW	224.0 kW
Frequency	60 Hz	Voltage	460 V
Current	330.0 A	Speed	3575 rpm
Service Factor	1.15	Phase	3
Efficiency	95.8 %	Power Factor	89
Duty	Continuous	Insulation Class	H
Design Code	B	KVA Code	G
Frame	447/449TS	Enclosure	Totally Enclosed Fan Cooled
Thermal Protection	No	Ambient Temperature	40 °C
Drive End Bearing Size	6313	Opp Drive End Bearing Size	6313
UL	Recognized	CSA	Y
CE	Y	IP Code	43

Technical Specifications

Electrical Type	Squirrel Cage Inverter Rated	Starting Method	Part Wdg Start & Wye Start Delta Run Or Inverter
Poles	2	Rotation	Reversible
Resistance Main	.0088 Ohms	Mounting	Rigid base
Motor Orientation	Horizontal	Drive End Bearing	Ball
Opp Drive End Bearing	Ball	Frame Material	Cast Iron
Shaft Type	TS	Overall Length	47.88 in
Frame Length	28.75 in	Shaft Diameter	2.375 in
Shaft Extension	5 in	Assembly/Box Mounting	F1/F2 CAPABLE
Connection Drawing	A-EE7300BH	Outline Drawing	B-SS519693-2875

This is an uncontrolled document once printed or downloaded and is subject to change without notice. Date Created:05/05/2020

4

3

Uncontrolled Copy

2

1

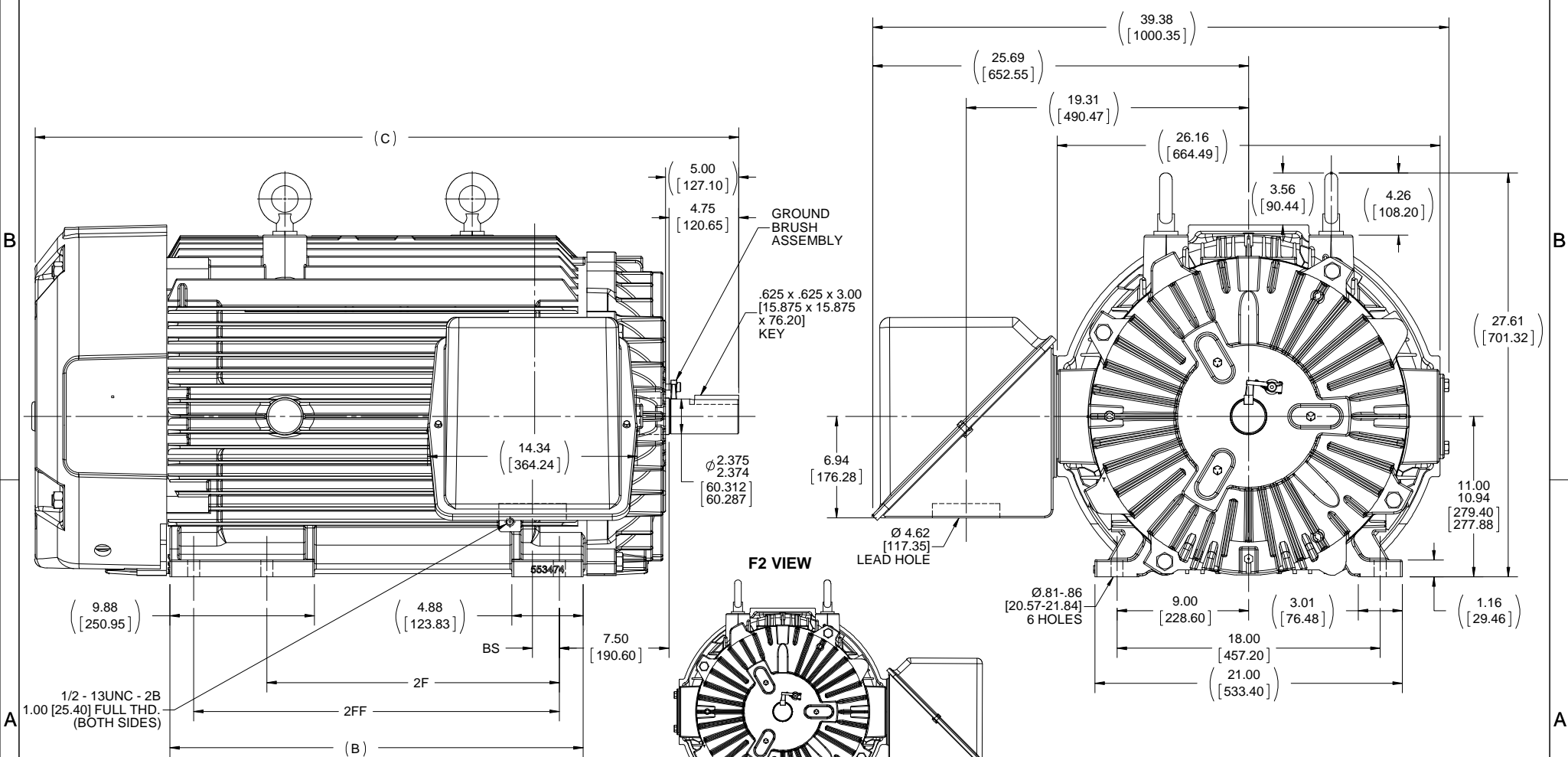

- NOTES:
 1. CONDUIT BOX CAN BE ROTATED IN 90° STEPS.
 2. NAMEPLATES TO BE READ FROM CONDUIT BOX SIDE OF MOTOR.
 3. DIMENSION IN [] DESIGNATE MILLIMETERS.

DASH	FRAME	B	C	2F	2FF	BS
2875	447TS	28.25 [717.55]	48.10 [1221.74]	20.00 [508.00]	---	1.84 [46.74]
2875	449TS	28.25 [717.55]	48.10 [1221.74]	---	25.00 [635.00]	1.84 [46.74]

DRAWING REVISION C	REVISION BY JJB	DATE 06-29-2017
ECO ECO-0125715	APPROVED BY JHA	DATE 06-29-2017
ECO DESCRIPTION ADDED F2 VIEW & UPDATED TO CURRENT STD'S		
<small>COPYRIGHT REGAL BELOIT AMERICA, INC. ALL RIGHTS RESERVED. PROPRIETARY AND CONFIDENTIAL INFORMATION - THIS DOCUMENT IS THE PROPERTY OF REGAL BELOIT AMERICA, INC. (OWNER) AND CONTAINS OWNER'S PROPRIETARY INFORMATION. ANY PERSON, CORPORATION OR OTHER FIRM RECEIVING IT IS DEEMED, BY RECEIVING IT, TO AGREE THAT IT, AND/OR ANY PART OF IT, SHALL NOT BE DISCLOSED TO ANY PERSON, CORPORATION OR OTHER ENTITY, DUPLICATED, AND/OR USED, EXCEPT AS EXPRESSLY APPROVED IN WRITING IN ADVANCE BY OWNER. THIS DOCUMENT SHALL BE RETURNED TO OWNER UPON REQUEST. IT MAY BE SUBJECT TO CERTAIN RESTRICTIONS UNDER APPLICABLE EXPORT CONTROL LAWS AND REGULATIONS.</small>		

TOLERANCES UNLESS OTHERWISE SPECIFIED:

DEC.	INCH	mm	ANGLE
.X	+0.1	[±2.5]	±7-30°
.XX	+0.03	[±0.76]	
.XXX	+0.005	[±0.127]	
.XXXX	+0.0005	[±0.0127]	

REMOVE BURRS & BREAK SHARP EDGES: .003/.015 [0.076/.381] X 45°
 CORNER FILLETS: R.02 [51]
 MACHINED SURFACES: 200 INCH/mm 5.1

DRAWN BY KL	DATE 03-25-2003
APPROVED BY JES	DATE 03-25-2003
REFERENCE	THIRD ANGLE PROJECTION

Regal Beloit America, Inc.	
DESCRIPTION OUTLINE 447/449TS FR. - TEFC - GRD. BRUSH	
MATERIAL	PROCESS/FINISH
SIZE B	DRAWING NUMBER SS519693
	SHEET 1 OF 1

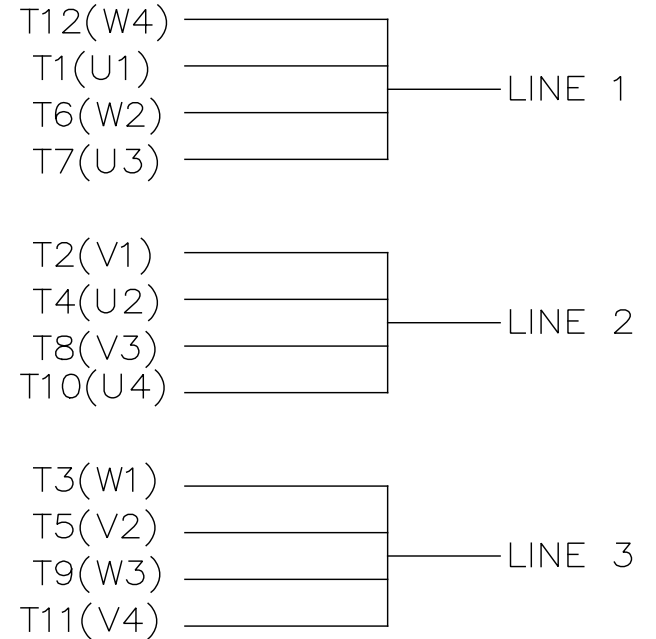
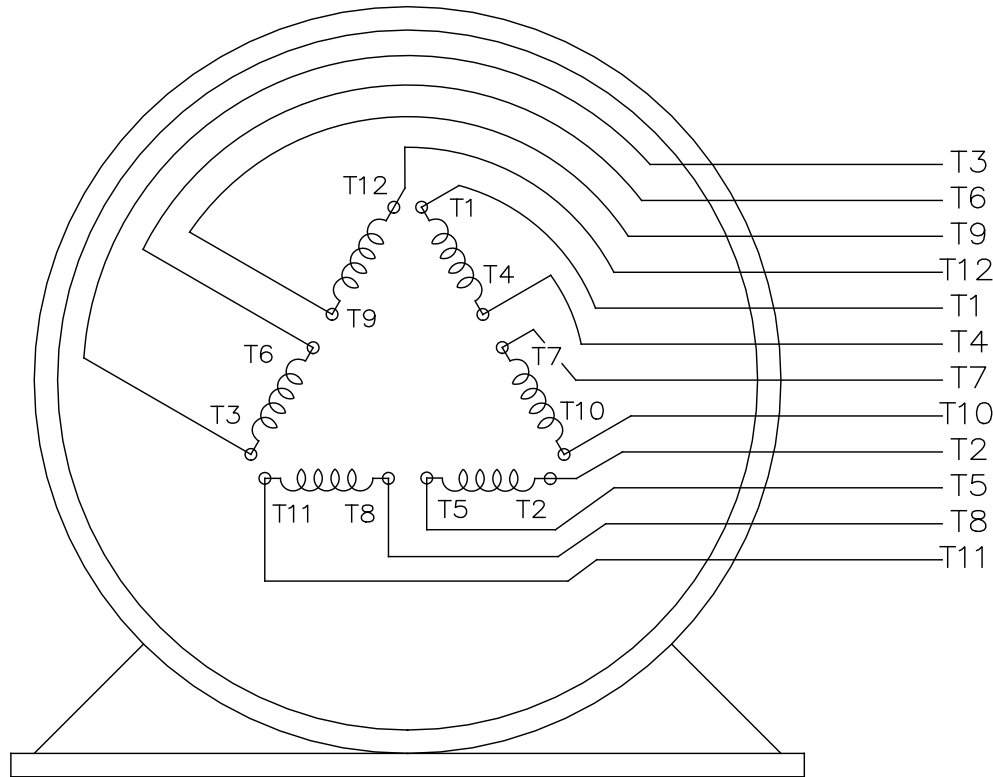

VIEW OF TERMINAL END

				TOLERANCES UNLESS SPECIFIED		REGAL REGAL - BELOIT CORPORATION	DRAWN RJW 02-11-2005			
				DEC.	INCHES		CHK	ML	02-11-2005	
				.X	±.1		APPD	GK	02-11-2005	
				.XX	±.02	TITLE CONNECTION DIAGRAM		SCALE		
D	CHANGED TO REGAL TITLE BLOCK	ECO-0108299	WGJ 08/22/2016	EMH	.XXX ±.005	12 LEAD- SINGLE VOLTAGE		REF		
1	ADDED IEC TERMINAL MARKINGS	CN 41429	JJB 05/24/2007	ML	.XXXX ±.0005	MAT'L.		FMF		
NO.	REVISION	BY & DATE	CHK	ANG	±7'30"	FINISH		PREV		
THIS DRAWING IN DESIGN AND DETAIL IS OUR PROPERTY AND MUST NOT BE USED EXCEPT IN CONNECTION WITH OUR WORK ALL RIGHTS OF DESIGN AND INVENTION ARE RESERVED THIS IS AN ELECTRONICALLY GENERATED DOCUMENT - DO NOT SCALE THIS PRINT				RFP	02-11-2005	CAD FILE ee7300bh	SIZE	DRAWING NO.	PAGE OF	REV.
				DIST	LB		A	EE7300BH		C

